

MX36-GCB Series

HIGH-AMP CIRCUIT BREAKER – PANEL MOUNT



MX36-GCB Series offers three types of panel mount high-amp circuit breakers. All are waterproof and meet IP67 standards.

MX36-GCB (shown): Type III, manual reset with switch, available with current ratings from 30–150Amps.

EXAMPLES OF MX36-GCB SERIES APPLICATIONS include:

- Auxiliary and accessory circuits
 - Trucks and Buses
 - Battery Chargers
 - Recreational Vehicles
 - DC Audio Systems
- ...and many more

MX36-GCB-A: Type III, manual reset, available with current ratings from 30–150Amps.

MX36-GCB-B: Type I, automatic reset, available with current ratings from 30–150Amps.

SPECIFICATIONS

■ Trip Time vs. Overload at 25°C

- At 100% of rated current: no trip
- At 135% of rated current: trip within 30 minutes
- At 200% of rated current: trip within 12-45 seconds
- At 300% of rated current: trip within 3.5–15 seconds

■ Current and Voltage Ratings

30A–150A, 42VDC maximum

■ Interrupt Capacity

3000A at 30VDC

■ Operating Temperature

-32°C to 82°C

■ Storage Temperature

-34°C to 149°C

■ Housing

Thermoset plastic, UL rated 94VO

■ Standard Testing

SAE J1625; SAE J1171
(ignition protected);
IP67 (waterproof)

■ Approvals

UL1500, RoHS compliant

TEMPERATURE DERATING CURVE

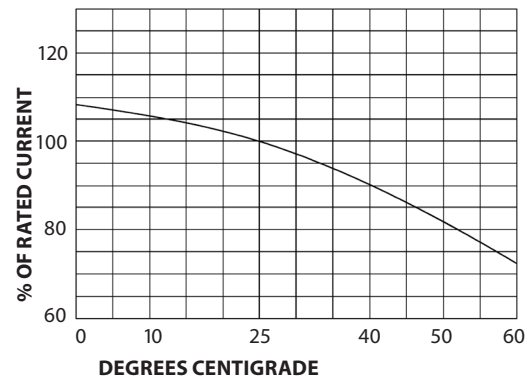

TRIP TIME CURVE

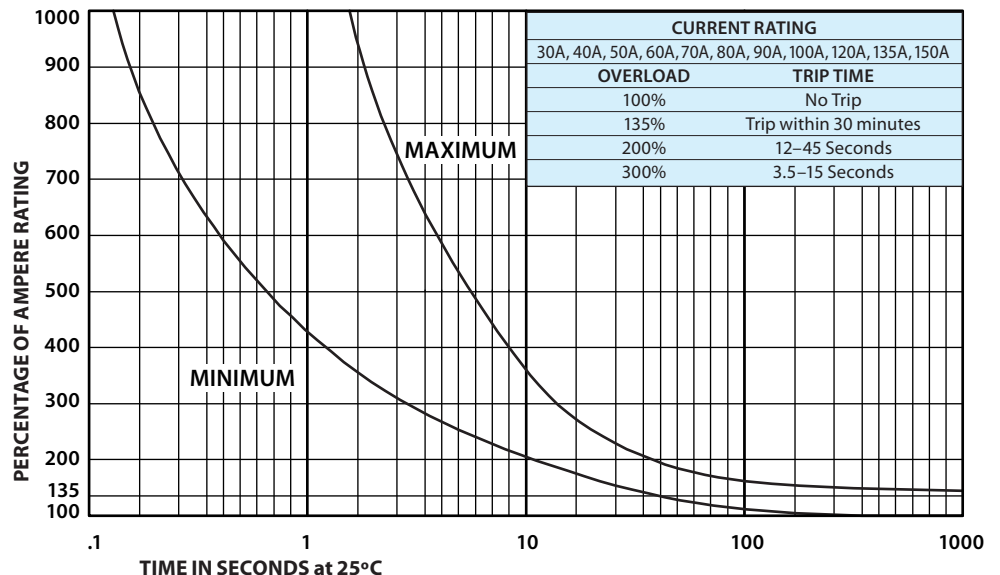

MX36-GCB Series

HIGH-AMP CIRCUIT BREAKER – PANEL MOUNT

DIMENSIONS in mm

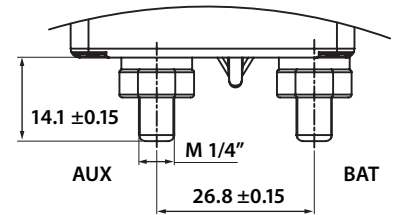
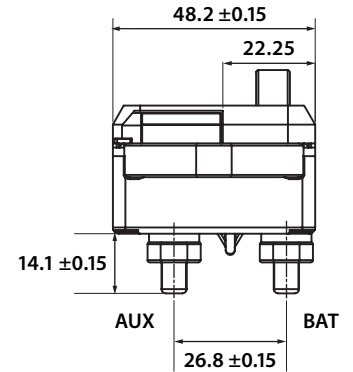
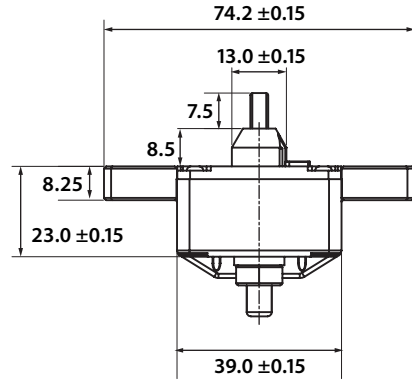
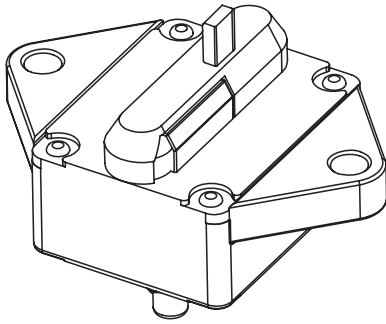

Stud size 1/4", 28 threads per inch
Use ring terminals

OPTIONS SELECTION

Series	Amps select by number	Amps select by number
MX36-GCB Manual Switch Reset		
High-Amp Circuit Breakers	30 30A 40 40A 50 50A 60 60A 70 70A 80 80A 90 90A	100 100A 120 120A 135 135A 150 150A



Series	Amps select by number	Amps select by number
MX36-GCB-A Manual Reset		
High-Amp Circuit Breakers	30 30A 40 40A 50 50A 60 60A 70 70A 80 80A 90 90A	100 100A 120 120A 135 135A 150 150A



Example: **MX36 GCB A 70**
MX36, Panel mount, Manual reset, 70 Amps

Series	Amps select by number	Amps select by number
MX36-GCB-B Automatic Reset		
High-Amp Circuit Breakers	30 30A 40 40A 50 50A 60 60A 70 70A 80 80A	90 100A 100 100A 120 120A 135 135A 150 150A



ACCESSORY

MX36-GCB/C
Cover Panel Mount
for MX36-GCB,
MX36-GCB-A,
MX36-GCB-B

Black rubber,
RoHS compliant



061610

TRIMAX
Circuit Protectors

A division of Pelco Component Technologies

2747 Route 20 East, Cazenovia, NY 13035
315-655-8476 ■ www.trimaxcb.com